

- SATCOM
- Communications (e.g. 5G)
- MIMO
- Phased Array Radar
- Synthetic Aperture Radar
- Cross Polarization

Direct RF Sampling Analog-to-Digital Converters

Directly sample input frequencies from DC to above 10 GHz. Two versions are offered, a single ADC chip FMC+ module and a dual ADC chip version. A single ADC chip can be configured for two channels in one ADC.

Up to 6.4 GSPS in single channel mode and up to 3.2 GSPS in dual channel mode. Analog input bandwidth (-3dB) is 8.0 GHz (Typ) and the usable input frequency range is >10 GHz.

JESD204B output interface.

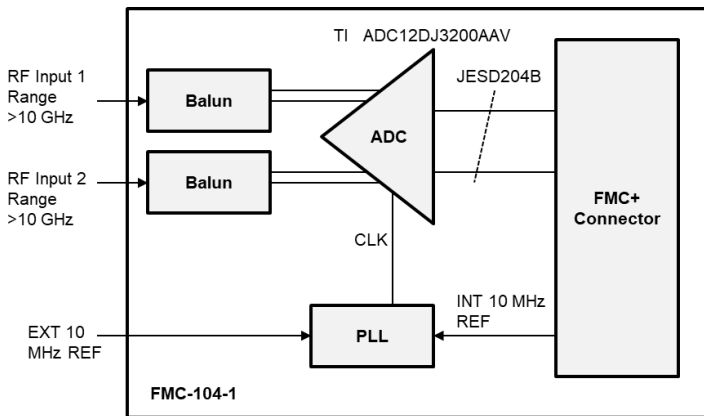

Single ADC Version P/N- FMC-104-1

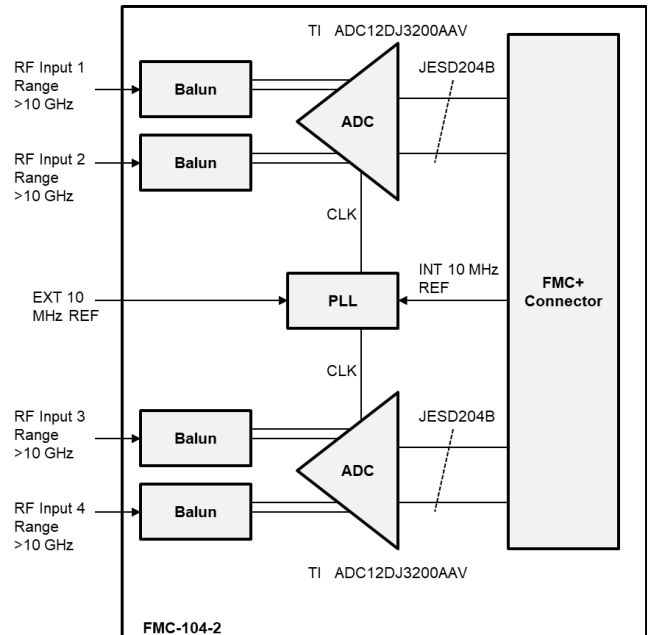

Dual ADC Version P/N- FMC-104-2

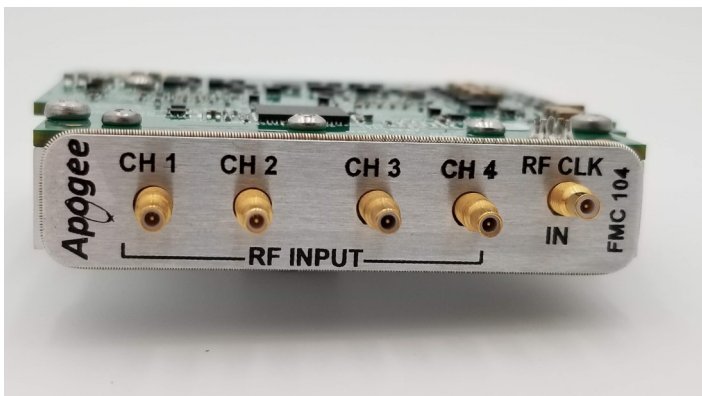

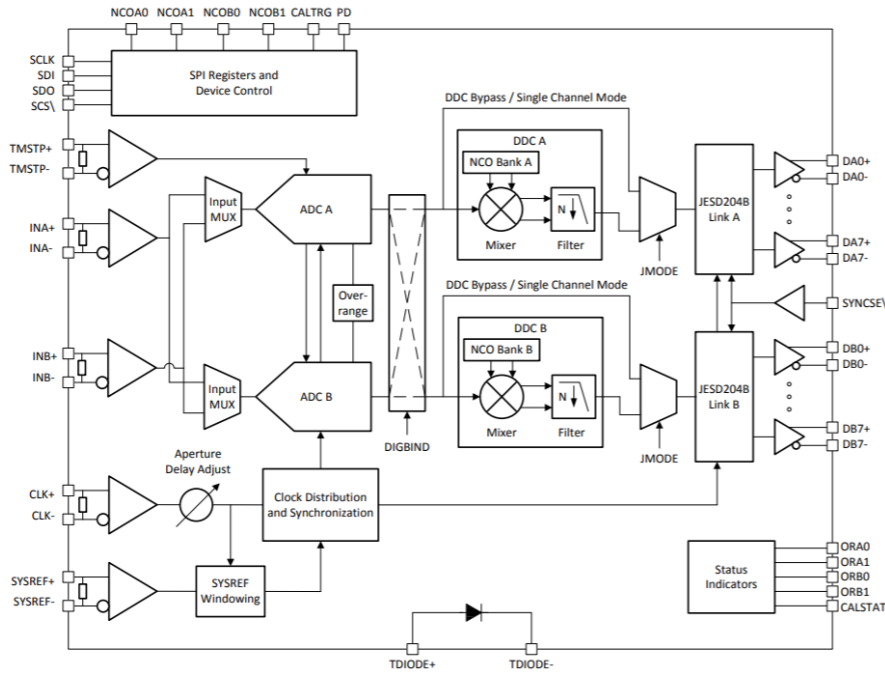

ADC Functional Block Diagram

Specifications (RF parameters are Typical)

Analog-to-Digital (ADC) Part Number.....	Texas Instruments ADC12DJ3200
ADC Resolution.....	12-bits
ADC Sampler Rate.....	Up to 6.4 GSPS Single Channel Mode, Up to 3.2 GSPS Dual Channel Mode
Analog Input Bandwidth.....	8.0 GHz (-3dB)
Usable Input Frequency Range.....	>10 GHz
Noise Floor (No signal, VFS = 1.0 VPP).....	Dual channel mode: -151.8 dBFS/Hz Single channel mode: -154.6 dBFS/Hz
Full-scale Input Voltage.....	0.8 Vpp (VFS, default)
JESD204B Serial Data Interface.....	Supports subclass 0 and 1 Maximum lane rate: 12.8 Gbps Up to 16 lanes allows reduced lane rate
DDCs in Dual Channel Mode.....	Real output: DDC bypass or 2x decimation Complex output: 4x, 8x or 16x decimation Four independent 32-bit NCOs per DDC
RF Input Connector Type.....	SSMC 50 Ohm
Form Factor.....	VITA 57.4 FMC+
Ordering Part Numbers.....	Single ADC P/N- FMC-104-1 Dual ADC P/N- FMC-104-2